



悬臂梁模块 (可适配数字传感器)

Weighing module with shear beam load cells
(Digital Version Available)

适用于GML-X8 S系列传感器;
结构紧凑, 安装简便;
适用于静载场合;
不锈钢及合金钢材质可选。

GML-X8 S series are apply to this module;
Compact installation, easy installation;
Suitable for static weighing;
Stainless steel and alloy steel selection.

单位Unit: mm

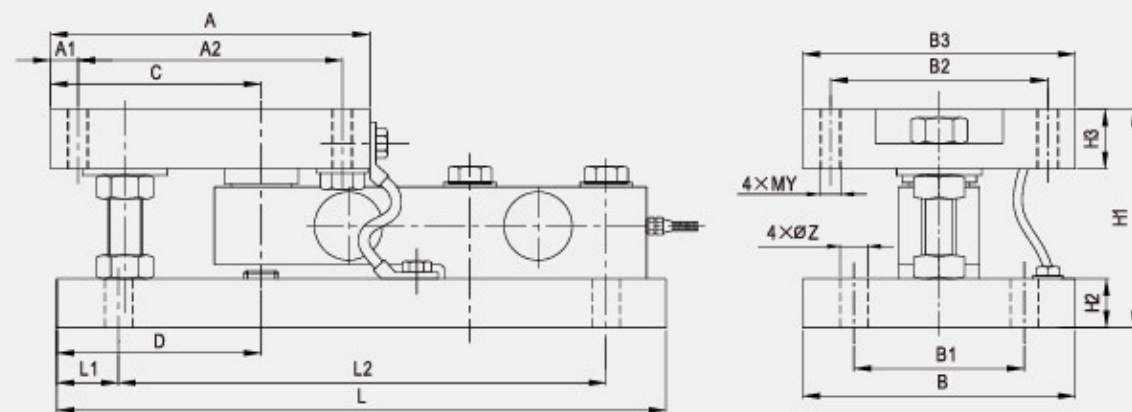

Cap(unit:t)	A	A1	A2	C	D	L	L1	L2	B	B1	B2	B3	H1	H2	H3	Y	Z
0.5,1,2	150	16	124	99	96	286	32	226	112	80	102	128	107	19	24	10	13
3	150	16	124	99	96	286	32	226	112	80	102	128	107	23	28	10	13
5,8	178	16	146	102	99	318	32	257	152	102	120	152	130	30	38	16	17
10,15	184	16	152	108	105	360	32	295	154	106	122	154	168	45	45	20	21

Mounting examples for weighing modules 安装方式

Radial install 径向方式

Cutting install 切向方式

Rectangle install 矩形方式

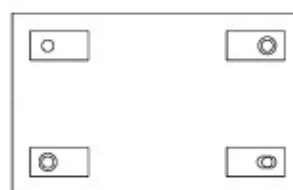
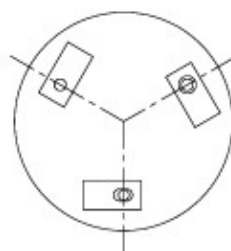
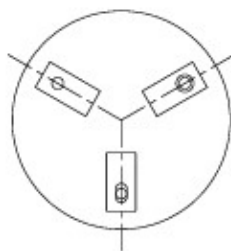

-  Fixed Module 固定式
-  Semi-float Module 半浮动式
-  Float Module 全浮动式