

# DYNAMIC CHECKWEIGHER CW-1.2K

- For pouches, bags, and soft-sided containers, bottles;
- S304 stainless steel frame is standard;
- 10-inch touch screen, can store over 1 million transactions, data export through USB;

## Multiple industrial application



Food



Grain



Chemical



High Cabinet



Low Cabinet



**1200g**  
Maximum capacity



**±0.5g**  
Best accuracy



**200 Pcs/min**  
Highest speed

## Standard specification

Model	CW-1.2K
Maximum capacity	1200g
Scale division	0.1g
Best accuracy*	±0.5g
Highest weighing speed*	200 pcs/min
Belt speed	5~50 m/min
Belt size	400x250mm
Weighing platform height *	750+100mm/-50mm
Belt material	PU (white)
Structure of the material	S304 stainless steel
Alarm light	3-color signal light (Red, yellow, green), Optional buzzer
Display size	10-inch color touch screen
Rejector lineup	Options: swing, air blow, push, flip, drop type
Power	Single Phase AC-220V±10%, 50/60HZ, 300W
Operating temperature	0~40°C
IP grade	IP54/IP65 Optional

\*Depend on the weight, size, and material of test object, Test accuracy: 1g at 120pcs/min.

## Dimensions

Unit:mm

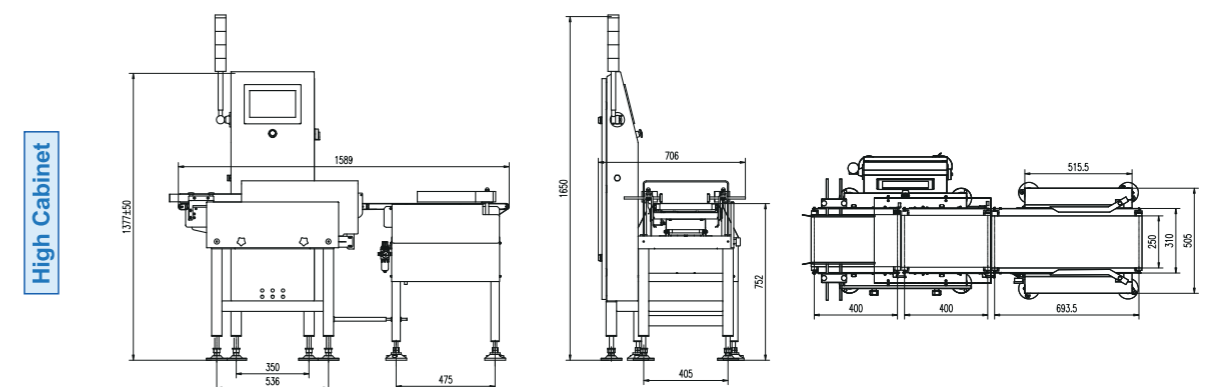
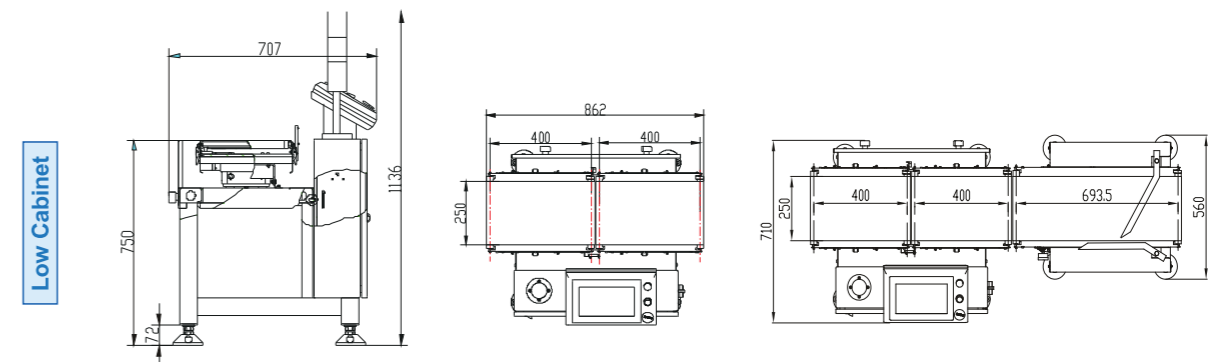

\*Specification and dimension may be upgraded, please consult sales manager for the latest info.