

DYNAMIC CHECKWEIGHER CW-100G

- This product is widely used in pharmaceutical production lines for highest weighing accuracy and repeatability;
- The checkweigher monitors manufacturing efficiencies and provides real-time data on your process;
- Product completeness and trends also provide feedback data to production line;
- It is also used in the application of checking completeness of secondary package to identify any missing items.

Multiple industrial application



Food



Pharmacy



Accessories



500g
Maximum capacity



±0.1g
Best accuracy



180 Pcs/min
Highest speed



Standard specification

Model	CW-100G
Maximum capacity	500g
Scale division	0.05g
Best accuracy*	±0.1g
Highest weighing speed*	180 pcs/min
Belt speed	5~60 m/min
Belt size	250x100mm
Weighing platform height *	830+100mm/-50mm
Belt material	PU (white)
Structure of the material	S304 stainless steel
Alarm light	3-color signal light (Red, yellow, green), Optional buzzer
Display size	10-inch color touch screen
Rejector lineup	Options: swing, air blow, push, drop type
Power	Single Phase AC-220V±10%, 50/60HZ, 225W
Operating temperature	0~40°C
IP grade	IP54/IP65 Optional

*Depend on the weight, size, and material of test object, Test accuracy: 0.1g at 100pcs/min; 0.3g at 180pcs/min.

Dimensions

Unit:mm

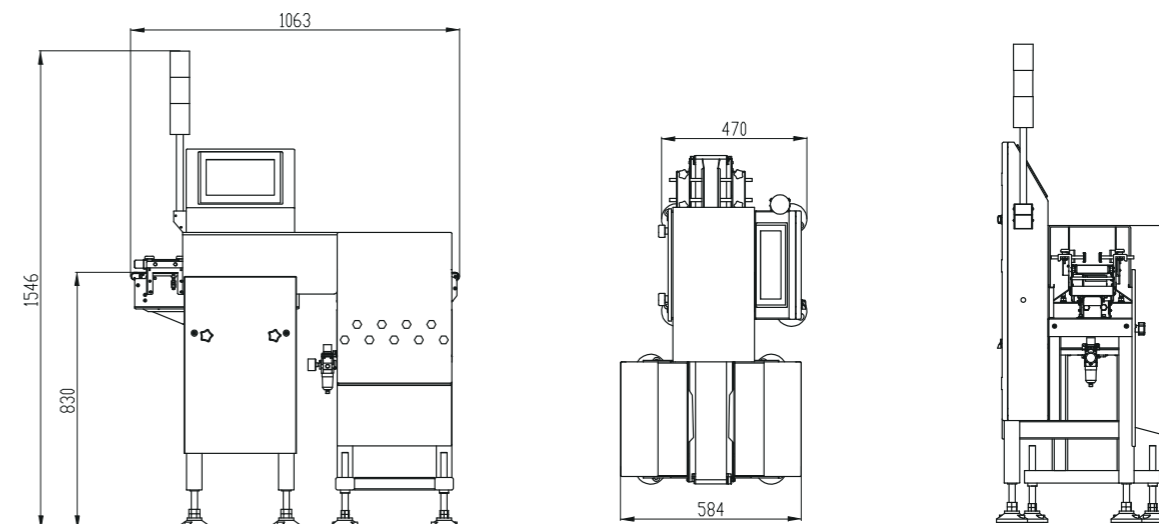

*Specification and dimension may be upgraded, please consult sales manager for the latest info.