

# DYNAMIC CHECKWEIGHER CW-100G Pro

- This product is widely used in pharmaceutical production lines for highest weighing accuracy and repeatability;
- The checkweigher monitors manufacturing efficiencies and provides real-time data on your process;
- Product completeness and trends also provide feedback data to production line;
- It is also used in the application of checking completeness of secondary package to identify any missing items.

## Multiple industrial application



Food



Pharmacy



Accessories



**500g**  
Maximum capacity



**±0.1g**  
Best accuracy



**300 Pcs/min**  
Highest speed



Standard specification	
Model	CW-100G Pro
Maximum capacity	500g
Scale division	0.05g
Best accuracy*	±0.1g
Highest weighing speed*	300 pcs/min
Belt speed	10~70 m/min
Belt size	200x150mm
Weighing platform height *	750+100mm/-50mm
Belt material	PU (white)
Structure of the material	S304 stainless steel
Alarm light	3-color signal light (Red, yellow, green), Optional buzzer
Display size	15-inch color touch screen
Rejector lineup	Options: air blow, push type
Power	Single Phase AC-220V±10%,50/60HZ,375W
Operating temperature	0~40°C
IP grade	IP65

\*Depend on the weight, size, and material of test object, Test accuracy: 0.1g at 120pcs/min; 0.2g at 200pcs/min.

## Dimensions Unit:mm

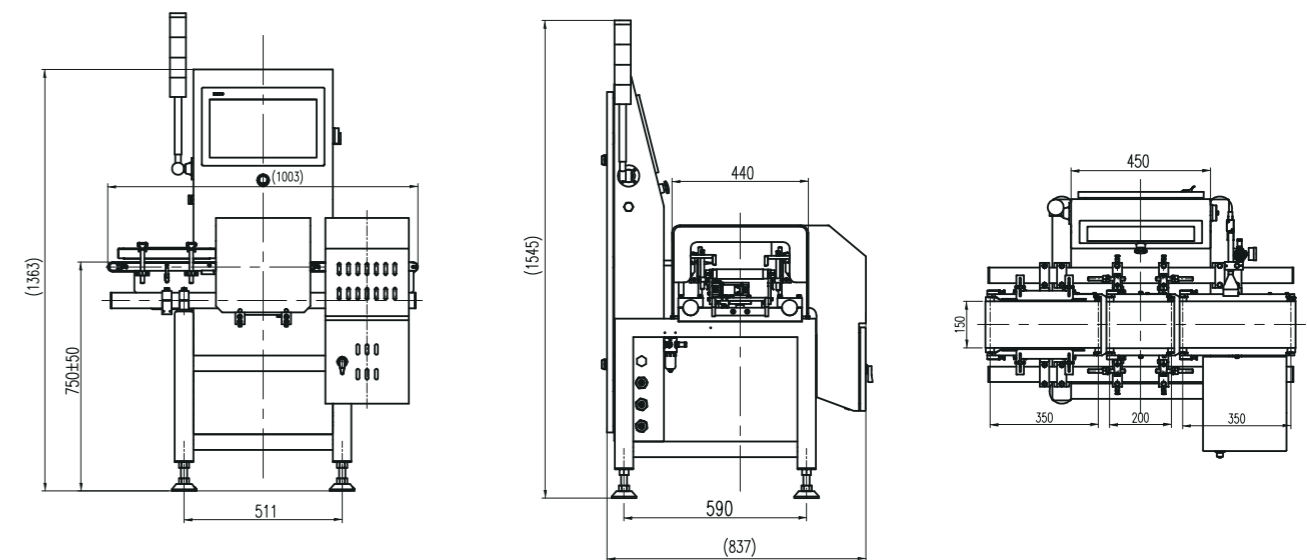

\*Specification and dimension may be upgraded, please consult sales manager for the latest info.